





Installation Instructions





UTV Soft Doors

Vehicle Application

- Arctic Cat Prowler
(use with p/n 20101)
2 Piece Soft Door Kit
Part Number: 20021

www.Bestoputv.com - We're here to help! Visit our web site and click on "[Ask a Question](#)". Click here for more [UTV Accessories by Bestop](#).

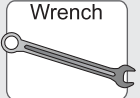
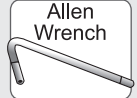
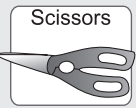
INSTALLATION TIME	SKILL LEVEL
 1/2 Hour	 2 - Moderately Easy

TOOLS			
 T30		 7/16" and 3/8"	 6mm
			

Installation Tips

Before you begin installing this assembly, read all instructions thoroughly.

For a smooth fit:

For ease in installation, the product should be installed at temperatures above 72° F. Below this temperature, the fabric may contract an inch or more, making it difficult to fit to the vehicle. It is normal for fabric to contract and wrinkle when stored in the shipping carton. Within a few days after the installation, the fabric will relax and the wrinkles will disappear.

 **CAUTION** Safety glasses should be worn at all times while installing this product.

 **WARNING** This product is designed primarily to enhance the appearance of the vehicle and to shield the occupants from ordinary weather conditions. Do not rely in any way on the components of this product to contain occupants within the vehicle, or to protect against injury or death in the event of an accident. This product will not protect the occupants from falling objects. Never operate the vehicle in excess of manufacturer's specifications.

WEAR SEAT BELTS AT ALL TIMES

Read and follow, precisely, all installation instructions provided when installing product. Failure to do so may result in a poor fit and could place occupants of the vehicle in a potentially dangerous situation.

UTV Soft Doors – Installation Instructions

Parts List and Hardware Identification

Adhesive Hook Strip, 118"	Qty - 1
Upper Door, Rt.	Qty - 1
Upper Door, Lt.	Qty - 1
Lower Door, Rt.	Qty - 1
Lower Door, Lt.	Qty - 1

Latches, Paddle Handle, Part Number 245.46, Qty - 2

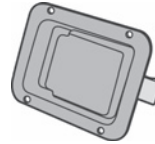

Door Hinge, Part Number 435.40, Qty - 4

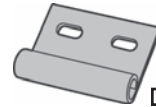

Small Clamp, Part Number 450.44, Qty - 2



A-Pillar Frame - Lt., Part Number 449.45, Qty - 1



A-Pillar Frame - Rt., Part Number 449.44, Qty - 1



A-Pillar Fabric - Rt., Part Number 453.60, Qty - 1

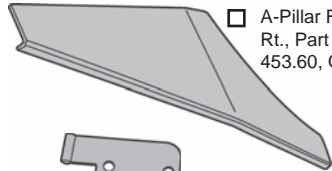

Door Latch, Part Number 450.47, Qty - 2

A-Pillar Fabric - Lt., Part Number 453.61, Qty - 1

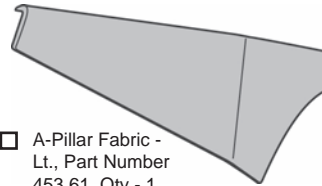

1/4" Lock Washer, Qty - 10, Part Number 397.21



1/4-20 x 1-1/4" Pan Head Screw, Qty - 10, Part Number 397.22

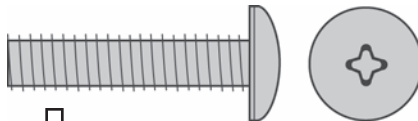

1/4-20 Hex Nut, Qty - 10, Part Number 397.20

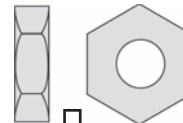

#10-24 Truss Head Machine Screw - Black, Qty - 10, Part Number 195.92

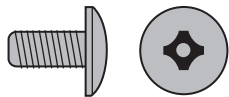

#10-24 Locknut, Qty - 10, Part Number 195.93

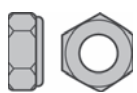

Allen Wrench, Qty - 1, Part Number 276.68

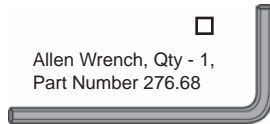

M8 x 25mm Screw, Qty - 4, Part Number 431.69

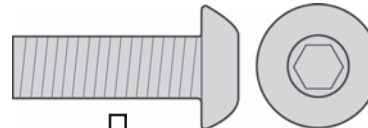

1 Open Vehicle Hood

Open the hood of the vehicle before starting the installation.

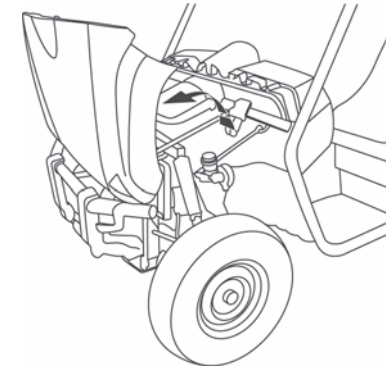

2 Remove Bolt

Remove the bolts in the lower front support cage on both sides of the vehicle. Set them aside to be reused.

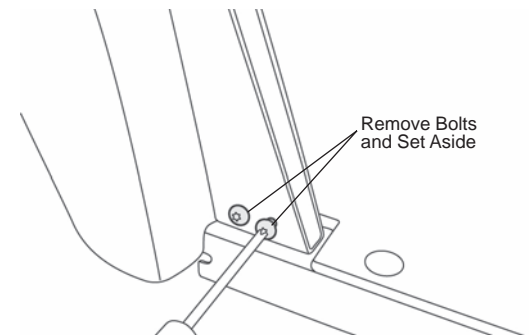

UTV Soft Doors – Installation Instructions

3 Install Small Clamp on Front Support Tube

Slide one (1) Small Clamp on to the front support cage on both sides of the vehicle.

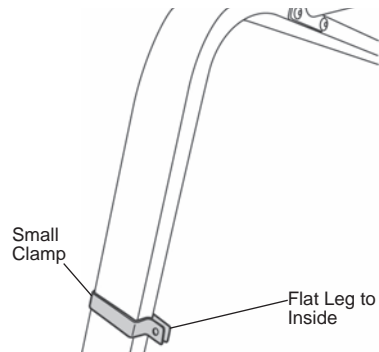

4 Install A-Pillar

Use the bolts removed in Step 2 to secure the bottom of the A-Pillar to the vehicle. Mount the top of the A-Pillar to the Small Clamp with a 1/4-20 x 1-1/4" Pan Head Screw, 1/4" Flat Washer and 1/4-20 Hex Nut. Repeat on both sides.

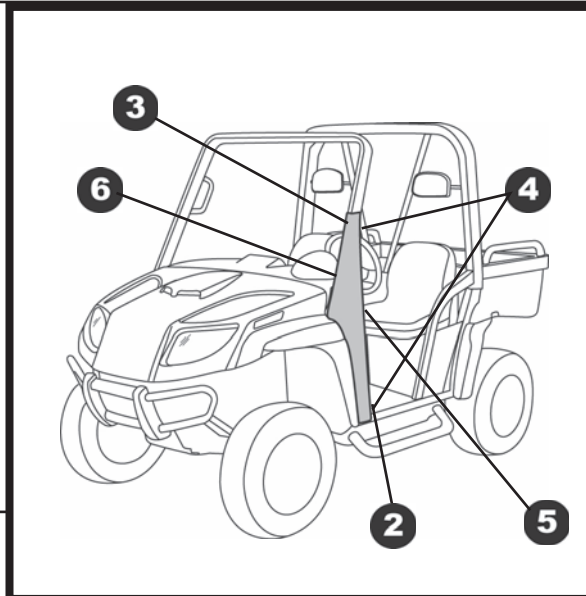
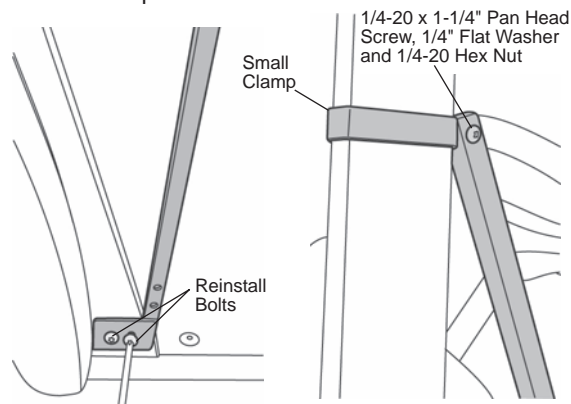

5 Install Adhesive Hook on A-Pillar

Clean the inside face of the A-Pillar with a 50% Water/Alcohol Solution. Cut a piece of Adhesive Hook Strip to fit. Peel the backing off the hook and press it firmly into place. Repeat for both A-Pillar Frames.

NOTE Allow 72 hours for the adhesive to set. Avoid unnecessary fastening and unfastening of the Cab Enclosure during this period.

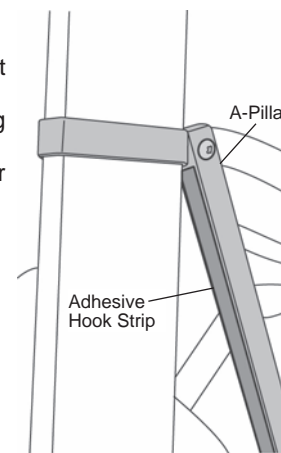

6 Install Adhesive Hook on Support Tube

Fasten the A-Pillar Cover to the A-Pillar. Fasten Adhesive Hook Strip to the remaining loop sewn to the cover. Clean the area where this Adhesive Hook Strip will be installed on the Support Tube with a 50% Water/Alcohol Solution. Wrap the cover around the Support Tube, peel the backing off and press the hook strip firmly into place. Repeat on both sides.

NOTE Allow 72 hours for the adhesive to set. Avoid unnecessary fastening and unfastening of the Cab Enclosure during this period.

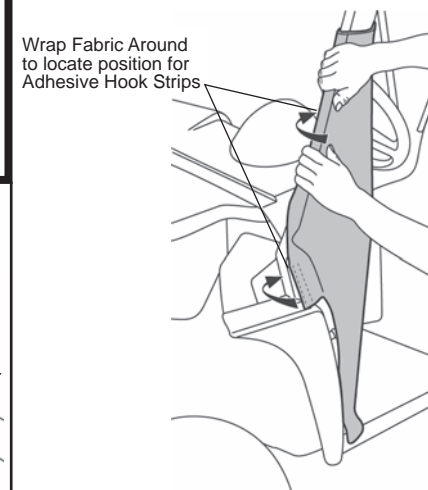

UTV Soft Doors – Installation Instructions

7 Install Door Hinges

Punch holes in the A-Pillar Cover to match the holes in the A-Pillar. Install two (2) Door Hinges with two (2) 1/4-20 x 1-1/4" Pan Head Screws, 1/4" Lock Washers and 1/4-20 Hex Nuts for each hinge. Repeat with both A-Pillar Assemblies.

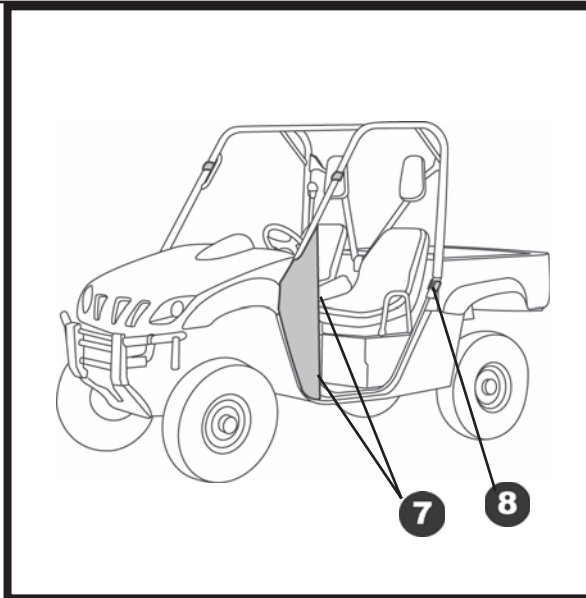
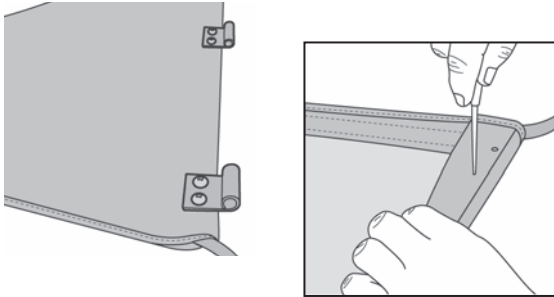

9 Install Fabric on Door Frame (Upper or Lower)

Orient the fabric to the frame. Start with the corner that does not have a circular relief in it. Then slide the rest of the frame into the fabric and secure the hook and loop.

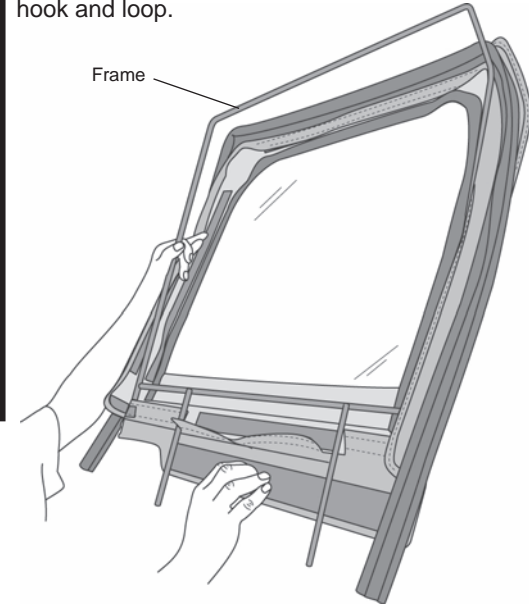

8 Install Door Latches

Use two (2) M8 x 25mm Screws to mount the Door Latch to the rear support cage. Repeat on both sides.

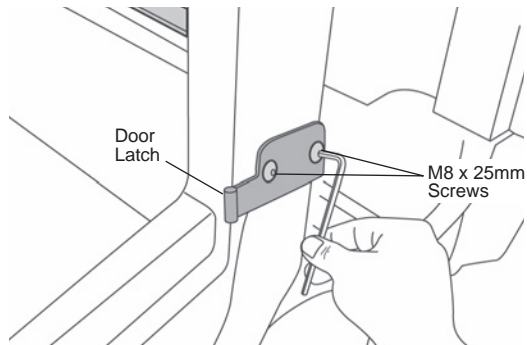

! WARNING The doors in this product are designed only for protection against the elements. Do not rely on the doors to contain occupants within the vehicle or to protect against injury during an accident. Door handles are only designed to aid in door closure. Door and handle will not support a person's weight.

UTV Soft Doors – Installation Instructions

10 Install Paddle Handle

Locate the pre-cut "X" in the lower door panel where the Paddle Handle will fit into the mounting plate on the door frame. Fold the pre-cut fabric back and insert the Paddle Handle into the mounting plate so that the latch mechanism is inside of the vehicle and the latch bolt is toward the rear of the door. Align the four holes in the Paddle Handle Assembly with the four holes in the mounting plate. Use a utility knife to punch four holes in the fabric to match the holes in the Paddle Handle and the mounting plate. Insert four #10-24 Truss Head Machine Screws from the outside and secure them with #10-24 Locknuts. Do not tighten the screws until adjustment in Step #2.

Important: You should check alignment of the Paddle Handle to the steel latch pin before tightening the screws. If out of alignment, align and retighten the screws securely.

Trim the excess fabric around the Paddle Handle. Repeat for both lower doors.

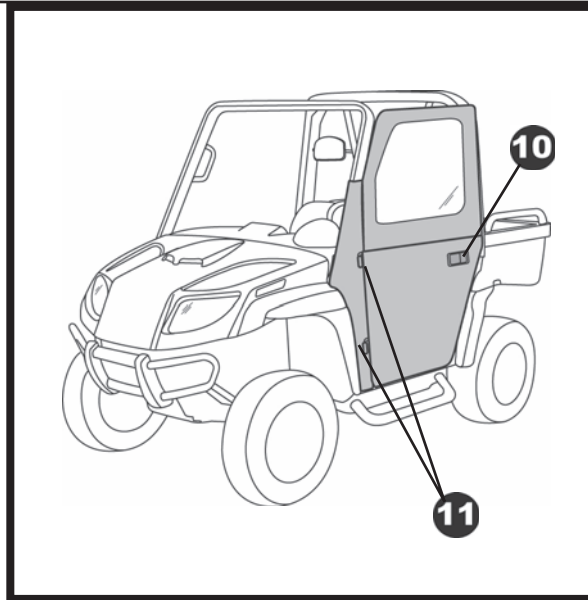
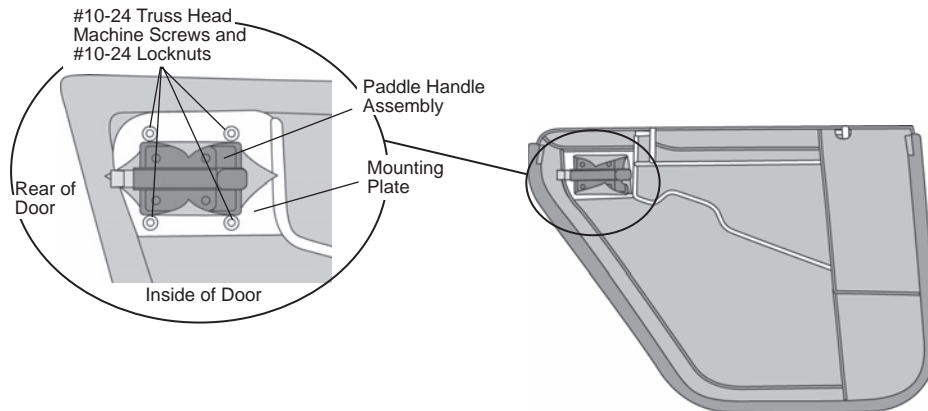

11 Install Door

Hold the door open and perpendicular to the vehicle with the hinge pins over the body hinges. Lower the pins into the hinges. Make sure that the pins are fully inserted into the body hinges. Close the door and check all sides to make sure that the door fits properly against the body. The latch can be adjusted for the best contact to the latch pin by loosening the four mounting screws and sliding the latch forward or rearward. Tighten all screws after the adjustment.

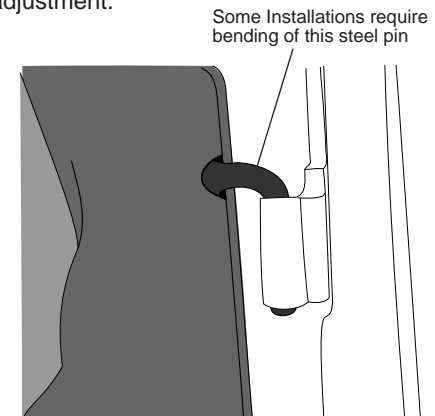

UTV Soft Doors – Installation Instructions

12 Adjust Door

Locate the Lower Hinge Pin Adjustment Plate on the Door frame. If the Door needs to be adjusted for a better fit against the body, use a 7/16" Wrench to loosen the two nuts in the adjustment plate. Slide the Hinge Pin backward or forward as necessary for the best fit. Tighten the nuts.

NOTE If the lower door pivot does not provide enough adjustability for correct latch adjustment (the door does not latch properly), follow the instructions in the enclosed spacer kit.

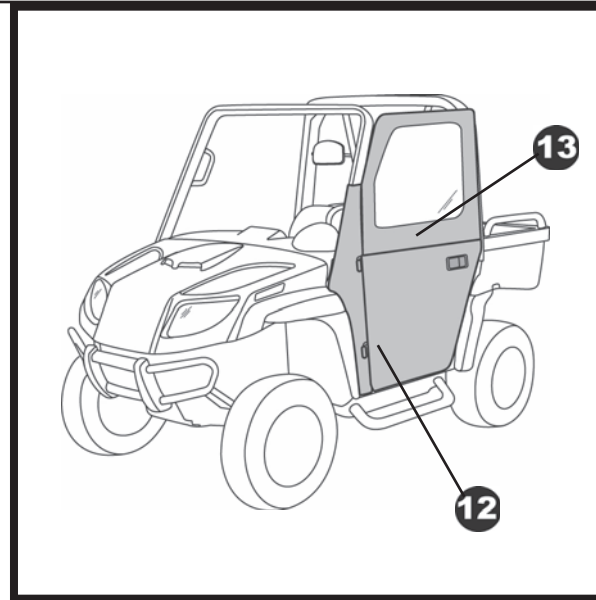
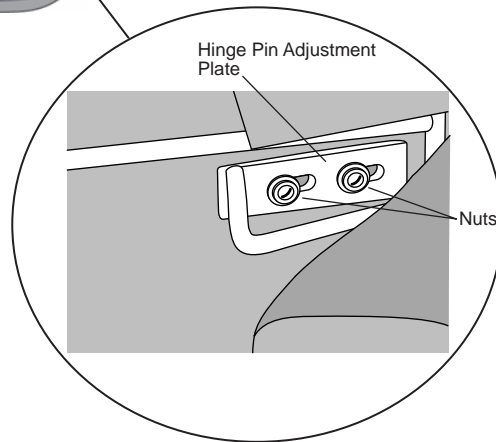
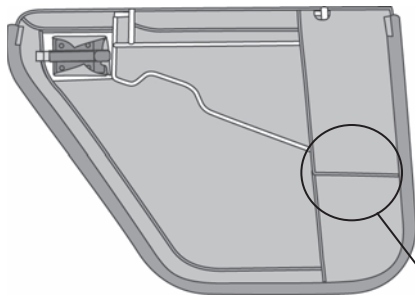

13 Install Upper Door

Install the upper door into the lower door. Starting with the front pin, slip the pins into the sockets in the lower door. Make sure that the pins are well seated in the sockets. Close the door to check that it fits properly against the body. If necessary, use a 1/8" Allen Wrench to loosen the Collars on the front and rear upper door pins. The Collars will slide up or down as needed to provide the best fit of the Upper Door against the windshield. Attach the loop strip on the bottom of the upper door to the hook strip on the top of the lower door. If necessary bend the door slightly for proper door fit.

NOTE Lubricate the upper door pins with a light weight oil to make it easier to install and remove the upper door.

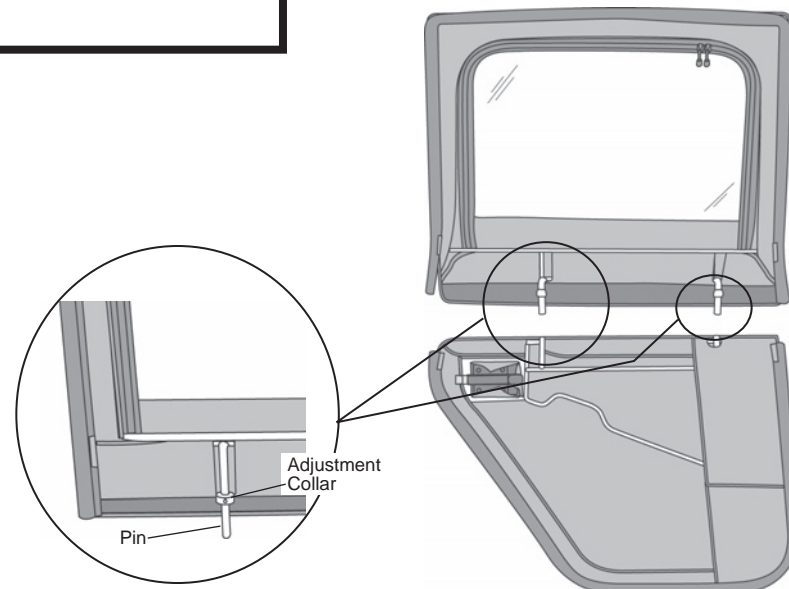

UTV Soft Doors – Installation Instructions

Care and Maintenance of your Bestop Product

Your Bestop product is made of the finest materials available. To keep it looking new and for the maximum possible wear, it will need periodic cleaning and maintenance.

Washing: The fabric should be washed often using soap, warm water and a soft bristle brush. Rinse with clear water to remove all traces of soap or use Bestop-recommended Bestop Cleaner and Bestop Protectant. Bestop Cleaner and Bestop Protectant are specially formulated to provide a total cleaning and protection system. Bestop Cleaner will not harm vehicle finish, is biodegradable and environmentally friendly. Bestop Protectant protects against UV-fading, cracking and hardening.

Zippers: Keeping the zipper cleaned and lubricated with a silicone lubricant will help prevent damage and keep the zippers in a smooth working condition. If a zipper opens behind the slider, the slider may have been spread apart. This problem can usually be repaired by using an ordinary pair of pliers to bring the sides back into parallel. Return slider to the end of the zipper in the normal Open position. Squeeze lightly at first and test the zipper. If the zipper continues to remain open squeeze more firmly with the pliers and try the zipper again. Repeat this procedure until the zipper operates correctly.

Water: Seeping through at the seams may be stopped by applying 3-M Scotchgard® on the inside of the seams. Rips in the fabric may be repaired with Bondex® iron on patches. Iron the patches to the Inside of the top, carefully following the Bondex® instructions.

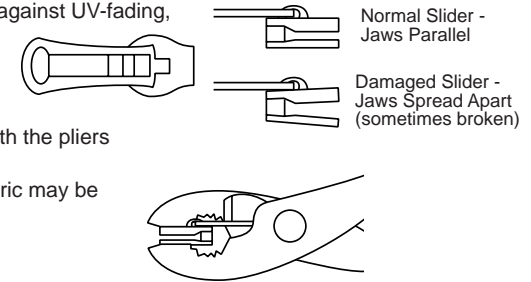

LIMITED WARRANTY

We warrant our product to be free from defects in material and workmanship, for the terms specified below, provided there has been normal use and proper maintenance. This warranty applies to the original purchaser only. All remedies under this warranty are limited to the repair or replacement of any item or items found by the factory to be defective within the time period specified. If you have a warranty claim, first you must call our factory at the number below for instructions. You must retain proof of purchase and submit a copy with any items returned for warranty work. Upon completion of warranty work, if any, we will return the repaired or replaced item or items to you freight prepaid. Damage to our products caused by accidents, fire, vandalism, negligence, misinstallation, misuse, Acts of God, or by defective parts not manufactured by us, is not covered under this warranty.

THE WARRANTY TIME PERIOD IS AS FOLLOWS FOR REPLACE-A-TOP™, SAILCLOTH REPLACE-A-TOP™, SUPERTOP®, SUPERTOP® REPLACEMENT SKINS, SUNRIDER®, AND TIGERTOP®: TWO YEARS FROM DATE OF PURCHASE.

THE WARRANTY TIME PERIOD IS AS FOLLOWS FOR ALL OTHER "SOFT GOODS" MANUFACTURED BY OUR COMPANY (USING PRIMARILY VINYL, PLASTICS, AND/OR FOAM): ONE YEAR FROM DATE OF PURCHASE.

THE WARRANTY TIME PERIOD IS AS FOLLOWS FOR ALL OTHER "HARD GOODS" MANUFACTURED BY OUR COMPANY (USING PRIMARILY METALS, PLASTICS, AND/OR FIBERGLASS): ONE YEAR FROM DATE OF PURCHASE.

ANY IMPLIED WARRANTIES OF MERCHANTABILITY AND/OR FITNESS FOR A PARTICULAR PURPOSE CREATED HEREBY ARE LIMITED IN DURATION TO THE SAME DURATION AND SCOPE AS THE EXPRESS WRITTEN WARRANTY. OUR COMPANY SHALL NOT BE LIABLE FOR ANY INCIDENTAL OR CONSEQUENTIAL DAMAGE.

Some states do not allow limitations on how long an implied warranty lasts, or the exclusion or limitation of incidental or consequential damages, so the above limitations or exclusions may not apply to you. This warranty gives you specific legal rights, and you may also have other rights which vary from state to state.



For further information or request for warranty work, please contact:
Bestop Inc., Customer Service
Toll-Free: (800)845-3567
Main: (303)465-1755
E-mail: csbestop@Bestop.com
Website: www.Bestop.com